

 **Intelligent Building Solutions**

CIB-tech

Installation Manual

CIB-tech®

Introduction

This document discusses the terms and devices that are related to the CIB-tech building automation system and gives the guide lines for installing the hardware of the CIB-tech system.

Terminology

CIB-tech -Complete Integration BUS technology:

A complex building automation system developed by Intelligent Building Solutions Ltd. It is based on the idea of integrating different stand alone equipments from different manufactures to form a building automation system with great diversity. The communication on the CIB-tech network is based on CAN bus.

CAN - Controller area network:

It is a message based protocol, developed by Robert Bosch GmbH, designed specifically for automotive applications but now also used in other areas such as industrial automation, building automation and medical equipment.

CIB-tech network/system:

An installed building automation based on Intelligent Building Solutions CIB-tech components. A CIB-tech network consists of one optional BackBone-BUS and one or more BUS-lines. The complete network can have a maximum of 127 addressable nodes, some optional non addressable nodes and one or more points of power input for powering the CIB-tech devices.

BB-BUS - CIB-tech Back-Bone BUS:

This is the main BUS line of the CIB-tech network. All the other BUS lines are connected to the BB-BUS via CIB-tech HUBs. The device connected directly to the BB-BUS are refers to Back-Bone devices (BBD).

The BB-BUS is called “zero length” if the BB-BUS is formed of a single CIB-tech HUB.

The BB-BUS is optional in a CIB-tech network. The simplest CIB-tech network in made up of one one single BUS-line without any CIB-tech HUBs.

BUS-line - CIB-tech BUS line:

In one CIB-tech network there are one or more BUS-line. The most CIB-tech devices are connected to these BUS-lines, sometimes these are referred to as BUS devices (BD)

Addressable devices:

These are the CIB-tech control and sensing devices. In a CIB-tech network most of the devices are addressable, these are also referred to as . All the other “non addressable devices” are necessary to keep the CIB-tech network functional.

Non addressable devices.

The devices that are necessary for the operation of the CIB-tech network, to connect in one network all the addressable devices. Non addressable devices are the CIB-tech HUBs, the CIB-tech - PC interfaces and the CIB-tech power injectors.

Cabling adapters:

Simple passive devices, used for adapting some CIB-tech devices to the CIB-tech network and for inserting power to the for the CIB-tech network. These devices can be both BUS devices and BB-BUS devices. They are non-addressable and do not take up power.

Linear/stellar network:

The CAN on witch the CIB-tech network is based has BUS type strictly linear structure. When we refer to stellar CIB-tech network in this document, we are referring to the star like cabling of the network. The communication in the network steal remains BUS like in the entire CIB-tech network.

Logical structure of the CIB-tech network

This part of the document describes the general structure of the CIB-tech network, giving a perspective for designing a CIB-tech network.

- One CIB-tech network can have a maximum number of 127 addressable device (both BUS and BB-BUS devices)
- The CIB-tech BB-BUS can have a maximum number of 120 devices (addressable and non addressable) – This is a theoretical limit. Due to the fact that most of the BB-BUS devices are CIB-tech HUBs and the maximum number of addressable devices is 127, in real installations the number of BB-BUS devices should not exceed 15-20 devices.
- The maximum length of the BB-BUS is 200m, but for optimal communication. It should be kept as short as possible.
- One CIB-tech BUS line can have a maximum number of 120 devices. If the given BUS line is connected to a CIB-tech HUB, the given HUB is also considered a device that is part of that BUS line so the maximum number of devices connected to a single BUS line of the HUB is 119. Note that in early implementations of the CIB-tech HUB(CHB23B and CHB24B) a pair of CIB-tech BUS connectors are connected to the same BUS line. Taking in to consideration that the maximum number of addressable devices on a CIB-tech network is 127 and any CIB-tech HUB, has at least 4 BUS lines, this limit should never be reached.
- The maximum length of a BUS line is 200m. Note that in early implementations of the CIB-tech HUB(CHB23B and CHB24B) a pair of CIB-tech BUS connectors are connected to the same BUS line.

Symbols used for illustrations:

- Addressable BUS device;
- ⊙ Non addressable BUS device;
- ▮ Cabling adapter: power injector
- ⚡ Power supply
- Addressable Back-Bone BUS device;
- ⊙ Non addressable Back-Bone BUS device: CIB-tech HUB
- CIB-tech BUS cable
- CIB-tech Back-Bone BUS cable

Simple linear CIB-tech network (Back-Bone less):

Example1 (Figure 1):

- 1 Cabling adapter - power injector – for powering the CIB-tech network;
- 9 CIB-tech BUS devices:
 - 1 Non addressable BD: CIB-tech - PC interface;
 - 8 Addressable BD

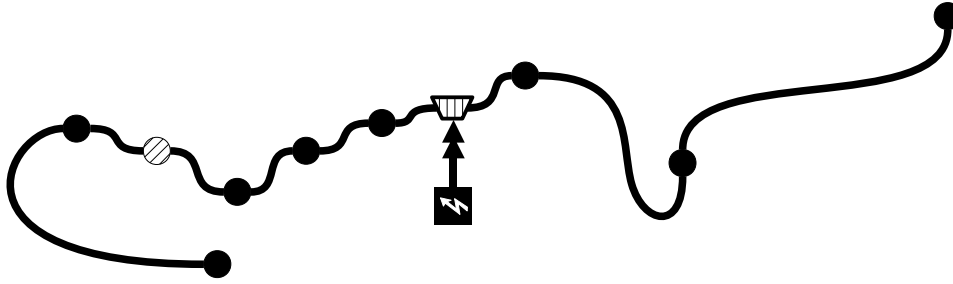

Figure 1

Example 2 (Figure 2):

- 2 Cabling adapters - power injectors – for powering the CIB-tech network;
- 16 CIB-tech BUS devises:
 - 1 Non addressable BD: CIB-tech - PC interface;
 - 15 Addressable BD

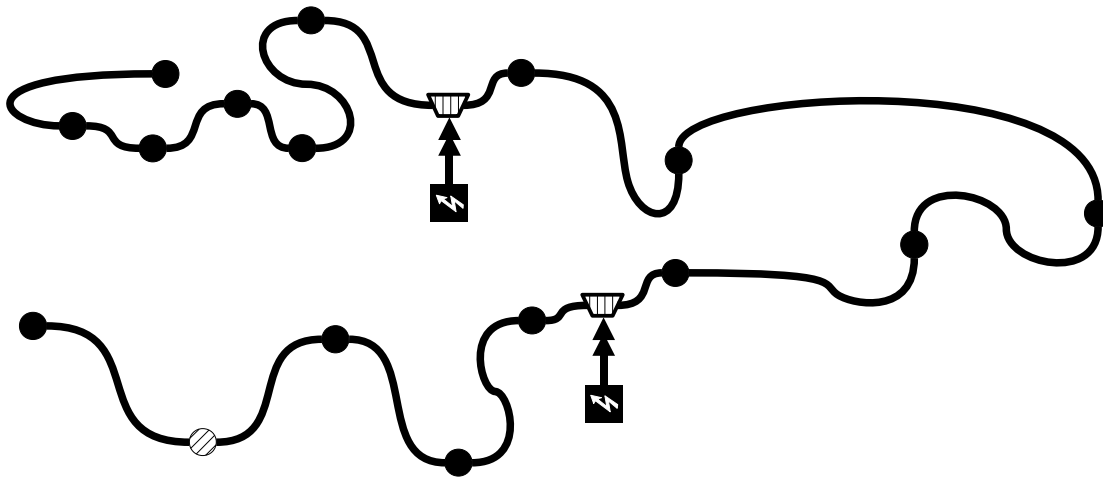

Figure 2

Simple stellar CIB-tech network (Zero length Back-Bone):

Example1 (Figure 3):

- 1 Non-addressable BB-D :CIB-tech HUB; This is also used for power powering the CIB-tech network;
- 14 CIB-tech BUS devises:
 - 1 Non addressable BD: CIB-tech - PC interface;
 - 13 Addressable BD

Example 2 (Figure 4):

- 1 Non-addressable BB-D :CIB-tech HUB; This is also used for powering most of to the CIB-tech network;
- 1 Cabling adapter - power injector – for powering a part of aCIB-tech BUS line;
- 16 CIB-tech BUS devises:
 - 1 Non addressable BD: CIB-tech - PC interface;
 - 15 Addressable BD

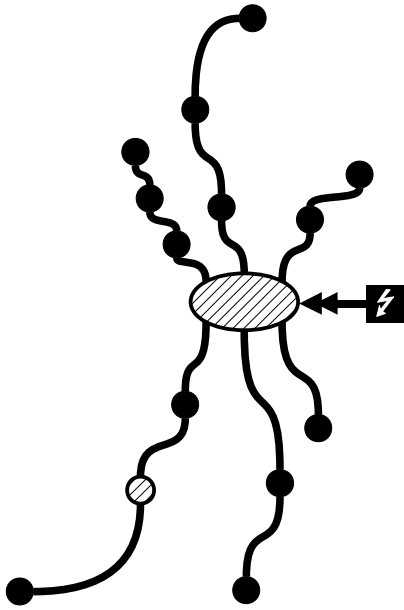

Figure 3

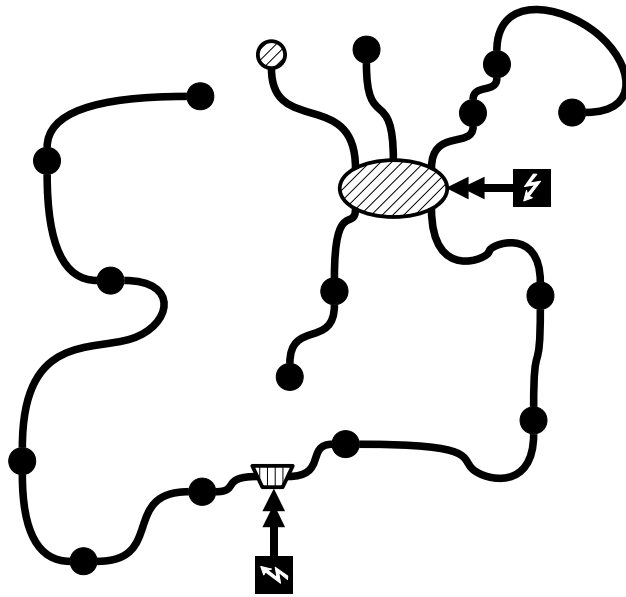

Figure 4

Complex stellar CIB-tech network:

Example 1 (Figure 5):

- 4 Back-Bone device
 - 3 Non-addressable BB-D :CIB-tech HUBs; Two of them are also used for powering most of to the CIB-tech network (including the third HUB an the BUS lines connected to it);
 - 1 Addressable BB-D;
- 42 CIB-tech BUS devises:
 - 2 Non addressable BD: CIB-tech - PC interfaces;
 - 40 Addressable BD;
- 1 Cabling adapter - power injector – for powering a part of aCIB-tech BUS line;

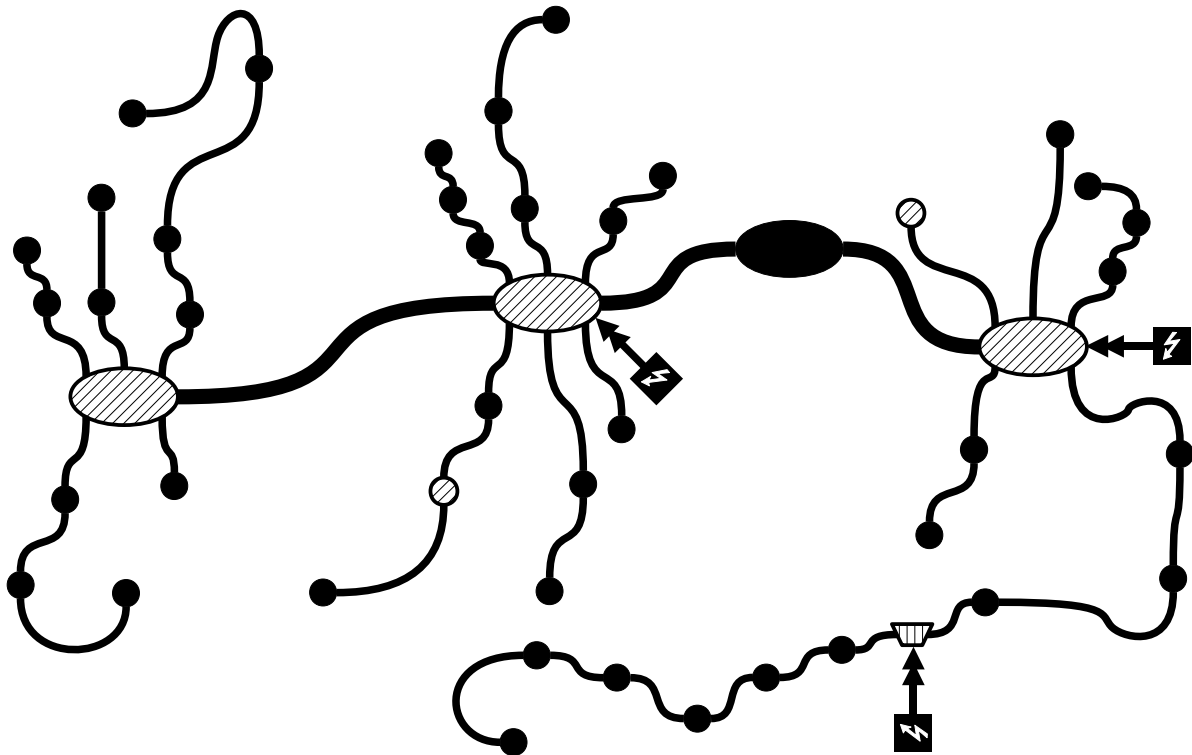



Figure 5

Detailed structure of the CIB-tech network

This part of the document describes in detail every part of the CIB-tech network, giving the technical information necessary of cabling and connecting a CIB-tech network. In this part of the document we do not make any difference between addressable and not addressable CIB-tech devices. A device is addressable or not is only important because of the 127 addressable device limit in one CIB-tech network.

The CIB-tech BUS elements:

CIB-tech power injector:

- simple passive adapter for adding power (extra power) to a CIB-tech BUS line;
- they are available with different power ratings and connectors see there individual data-sheet for details;
- symbols used in logical drawings: 
- symbols used in detailed drawings:

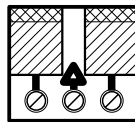

Generic CIB-tech BUS device:

- any addressable and non addressable device that is connected to a CIB-tech BUS line (sensing/control devices, CIB-tech - PC interfaces);
- every CIB-tech BUS device has a built in EOL (end of line) resistor that is connectable with switch or jumper. See the individual data-sheet of the given device to locate EOL (end of line) jumper/switch;
- there are CIB-tech BUS devices with one or two CIB-tech BUS connector. From the point of view of the cabling, the devices with the two CIB-tech BUS connectors are the general

ones. The devices with only one connector are either connected as the last element of a CIB-tech BUS line (in this case only one connector should be used anyway) or they are connected via a BUS-Linker that makes the device look like (from the point of view of the cabling) a two CIB-tech BUS connector device. So in this document all the devices are represented as (considered) two CIB-tech BUS connector devices.

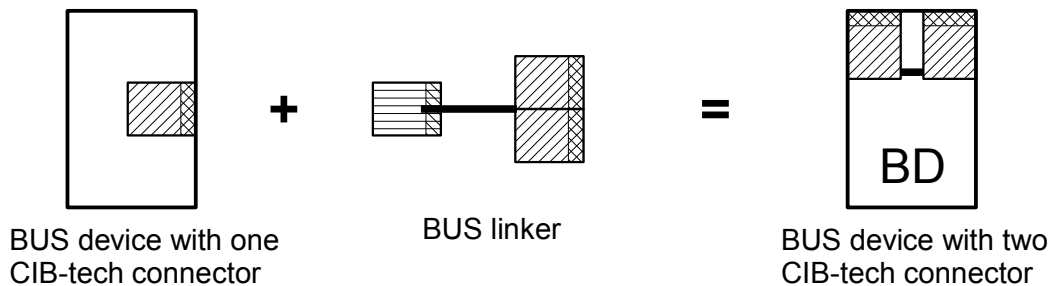

- symbols used in logical drawings: ● ⊙
- symbols used in detailed drawings:
BUS device with EOL resistor (jumper/switch) disconnected

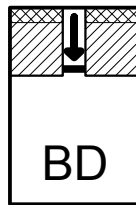

BUS device with EOL resistor (jumper/switch) connected

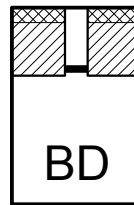

BUS device with EOL resistor (jumper/switch) disconnected

The CIB-tech Back-Bone BUS elements:

At the time of the creation of this document Intelligent Building Solution does not supply any generic CIB-tech Back-Bone device, only the dedicated ones which are treated individually.

CIB-tech HUBs:

- they are dedicated devices to connect together the CIB-tech BUS lines and connect them to the CIB-tech Back-Bone;
- they distribute power to the CIB-tech BUS lines;
- they have built in EOL (end of line) resistor for the BUS lines that are connected to it. In early implementations of the CIB-tech HUB(CHB23B and CHB24B) a pair of CIB-tech BUS connectors are connected to the same BUS line and as a result in these HUBs the EOL resistors must be switchable. See the data-sheet of these HUBs to determine the correct setting of these switches (if there is / isn't BUS line connected to it). In current implementation of the CIB-tech HUB every BUS connector corresponds to a BUS line and as a result every BUS line ends in the CIB-tech HUB so the BUS line EOL resistor is connected permanently to the BUS lines.
- the CIB-tech HUB has a built in BB-EOL (back-bone end of line) resistor that is connectable with switch or jumper. See the individual data-sheet of the given HUB to locate BB-EOL jumper/switch; Note that in early implementations of the CIB-tech HUB(CHB23B and CHB24B) has two switches for setting the BB-EOL resistor, make sure to set both correctly.

- symbols used in logical drawings:

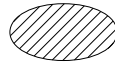

- symbols used in detailed drawings:

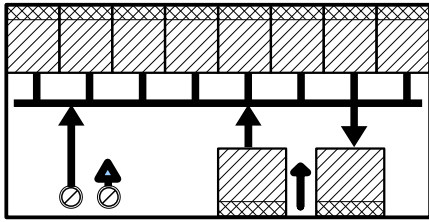

HUB with BB-EOL resistor
(jumper/switch) connected

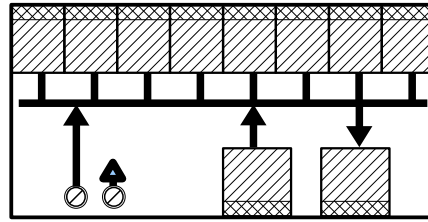

HUB with BB-EOL resistor
(jumper/switch) disconnected

- to simplify the drawings, there is no different symbol used for earlier and current implementation of HUBs. If the EOL/BB-EOL switches are set correctly, the CHB23B and CHB24B HUBs can be simplified as current HUBs with half as many BUS lines.

CIB-tech Supply monitor:

- this device is dedicated for monitoring the CIB-tech UPS type power supply and it is powered directly from the power supply that it monitors
- it can be used as a “power injector” for the BB-BUS. Depending on the state of the fuses (fuse inserted/removed) it supply's or doesn't supply's power for one, both directions on the BB-BUS. See the the power supply monitors data-sheet to identify the fuse - BB-BUS connector correspondence.
- it has built in BB-EOL resistor that is connectable via BB-EOL jumper. See the the power supply monitors data-sheet to locate the BB-EOL jumper on the device.
- symbols used in logical drawings:



- symbols used in detailed drawings:

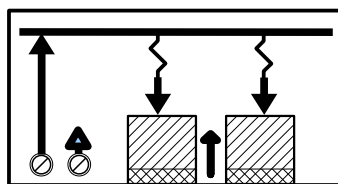

Both fuses on
BB-EOL jumper ON

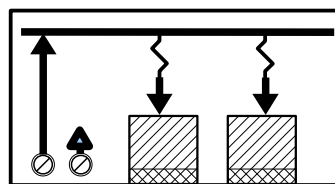

Both fuses on
BB-EOL jumper OFF

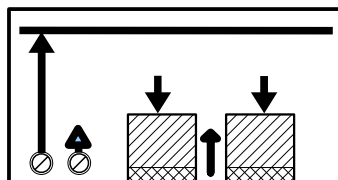

Both fuses OFF
BB-EOL jumper ON

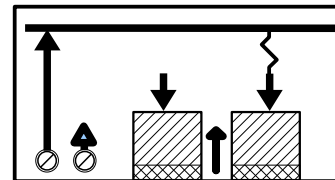

One fuses ON, one OFF
BB-EOL jumper ON

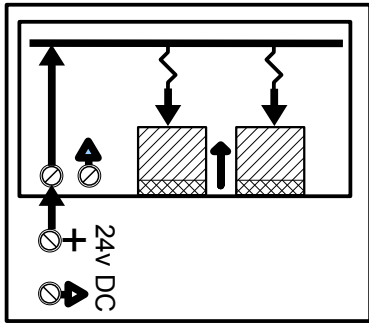

Power supply monitor mounted on power supply

Note that the power from the supply can be inserted in to the BB-BUS via the power supply monitors BB-BUS connectors but also available for general purpose use via the power supply's terminals

The CIB-tech power supplies:

- the nominal supply voltage of the CIB-tech network is 24v DC.
- The entire CIB-tech network has common ground, so care must be taken when using more than one power supply's for powering the CIB-tech network. It is strongly recommend to use power supply's with isolated (floating) output.
- depending on the type of the power supply, the supply voltage can vary. For example the CIB-tech UPS type power supply has an valid output voltage of 20v-28v DC.
- The voltage drop on the cable (from the power supply to the CIB-tech device) must be taken into consideration so the CIB-tech devices power requirements be met.
- Special care should be taken with the end devices (equipment that is connected to the CIB-tech devices) that are powered from the CIB-tech and have a nominal supply voltage of 24V. Some of these devices have a much tighter minimum-maximum supply voltage range than the CIB-tech device to witch it is connected. If the supply requirements for these end devices can not be met due to the voltage variation on the CIB-tech power supply and/or the voltage drop on the cable, they should be powered from separate power supply.

• symbols used in logical drownings: 

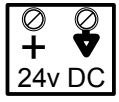
• symbols used in detailed drownings: 

The Back-Bone BUS

- This is the main BUS of the CIB-tech network and it's major role is to connect the CIB-tech HUBs.
- It can have a maximum number of 120 devices (addressable and non addressable) connected to it (the CIB-tech HUB counts as one device). Due to the fact that most of the BB-BUS devices are CIB-tech HUBs and the maximum number of addressable devices in a CIB-tech network is 127, the number of BB-BUS devices should not exceed 15-20 devices.
- The maximum length of the BB-BUS is 200m, but for optimal communication it should be kept as short as possible.

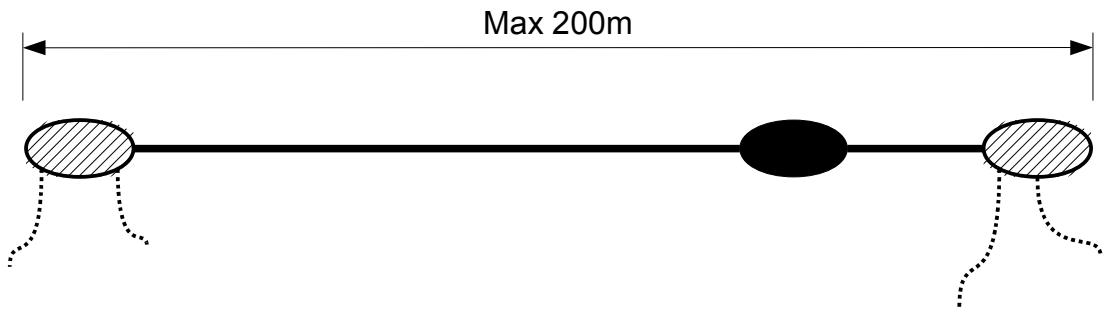

- No cable should be connected to the last BB-BUS devices unused BB-connector.
Warning: Such a situation can happen when the last BB device has to be removed for some reason. In this case the cable must be disconnected from the previous device as well.

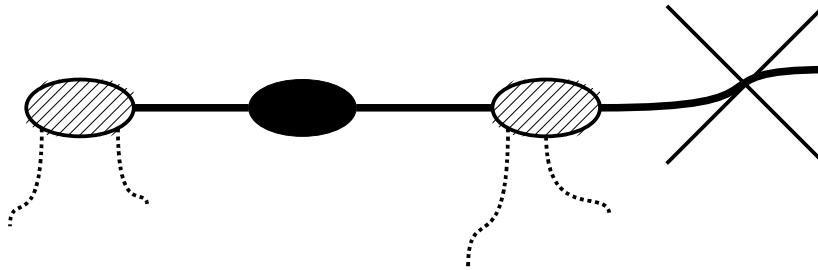

- The BB-EOL resistor must be connected at each end of the BB-BUS and no other BB-EOL resistor should be connected to the BB-BUS.

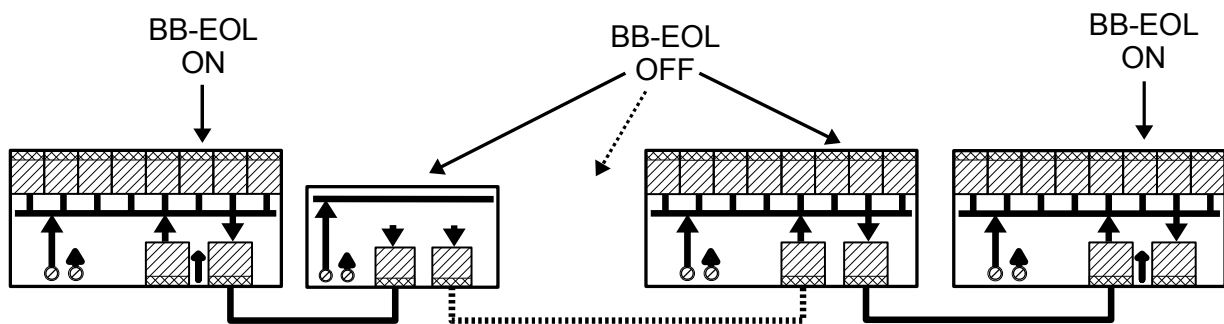

NOTE: to simplify the representation the BUS lines and power supply's are ignored.

In case of Zero length BB-BUS the BB-EOL must be on the HUB.

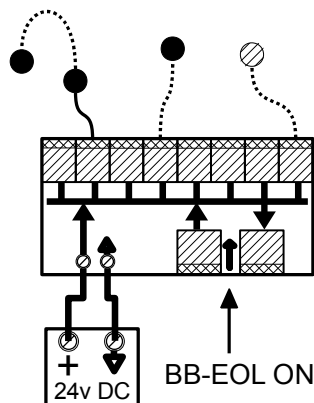

- The BB-BUS connector is 8P8C modular jack (RJ45)
- For the BB-BUS, 4 twisted pair AWG24 (UTP CAT3 or better) cable is used.
 - number of wires: 8 = 4 twisted pair;
 - conductor diameter: AWG24 = 0.5mm diameter
 - conductor type: rigid cooper wire
 - conductor resistance: 84 OHM/Km
 - maximum current: 1A/conductor

- Cable and connector pin-out (the same on both ends):

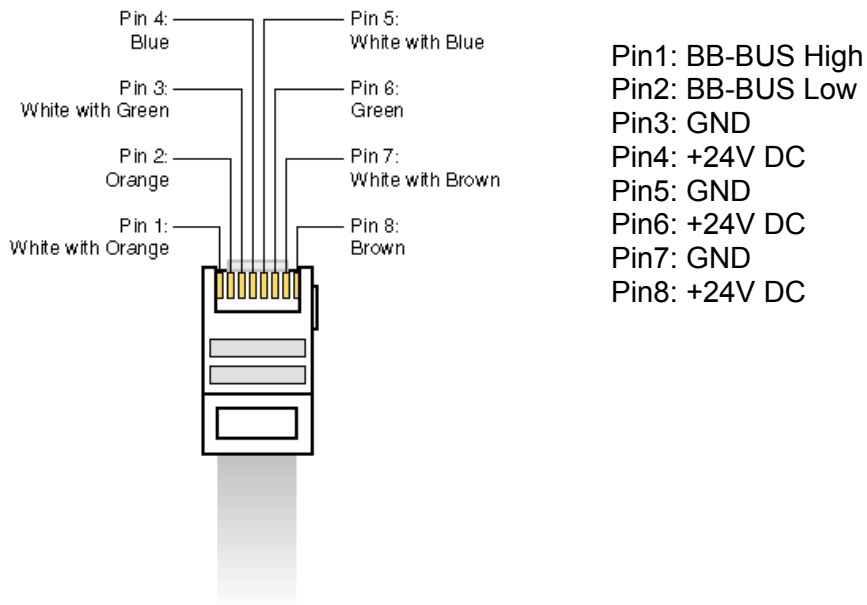

- One pair of BB cable is used for communication
- 3 pairs of BB cable is used for power transfer between BB equipments
 - equivalent resistance (two way): 55OHM
 - maximum current: 3A

The BUS line(s)

- The simplest CIB-tech network consists of a single BUS line, without any HUBs, without any BB-BUS. More complex CIB-tech networks consist of many BUS lines connected to one or more BUBs.
- This is the main BUS of the CIB-tech network and its major role is to connect the CIB-tech HUBs.
- One BUS line can have a maximum number of 120 devices (addressable and non addressable) connected to it. If the BUS line is connected to a CIB-tech HUB, it counts as a non addressable device on that BUS line.

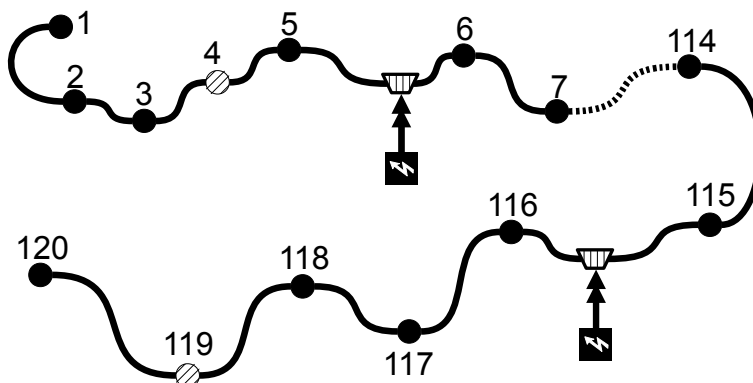

- The maximum length of a BUS line is 200m, but for optimal communication it should be kept as short as possible.

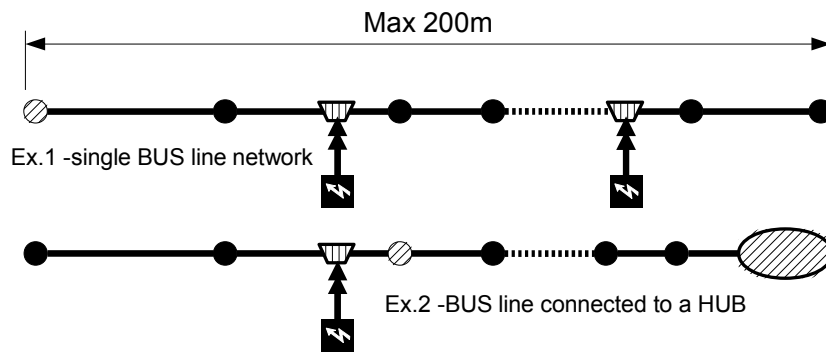

- No cable should be connected to the last BUS devices unused BUS-connector.
Warning: Such a situation can happen when the last device on the BUS line has to be removed for some reason. In this case the cable must be disconnected from the previous device as well.

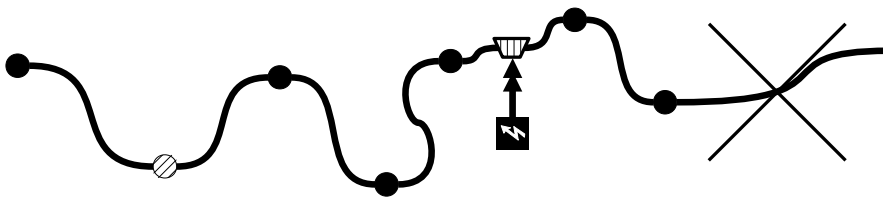

- One BUS line should never be connected to two HUBs nor to two different bus line connectors of a HUB.

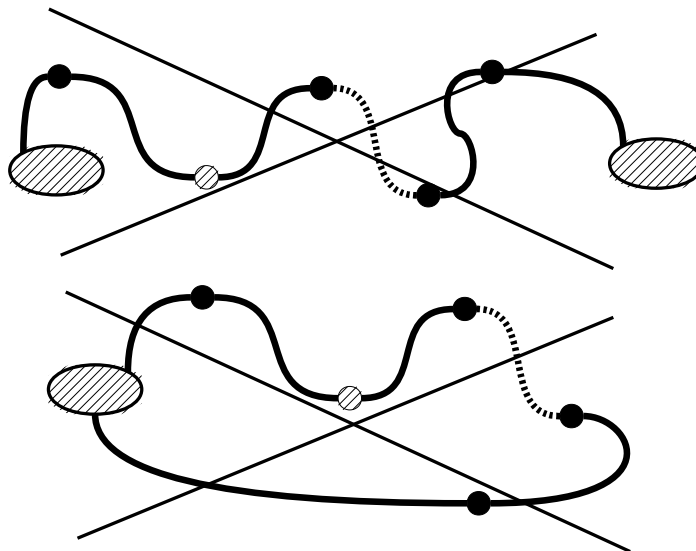

- The EOL resistor must be connected at each end of the BUS line and no other EOL resistor should be connected to that BUS line. If the BUS line is connected to a HUB, the end of the BUS line connected to the HUB has EOL resistor inside the HUB. Make shore that the EOL switches are set correctly when using CHB 23 B or CHB 24 B.

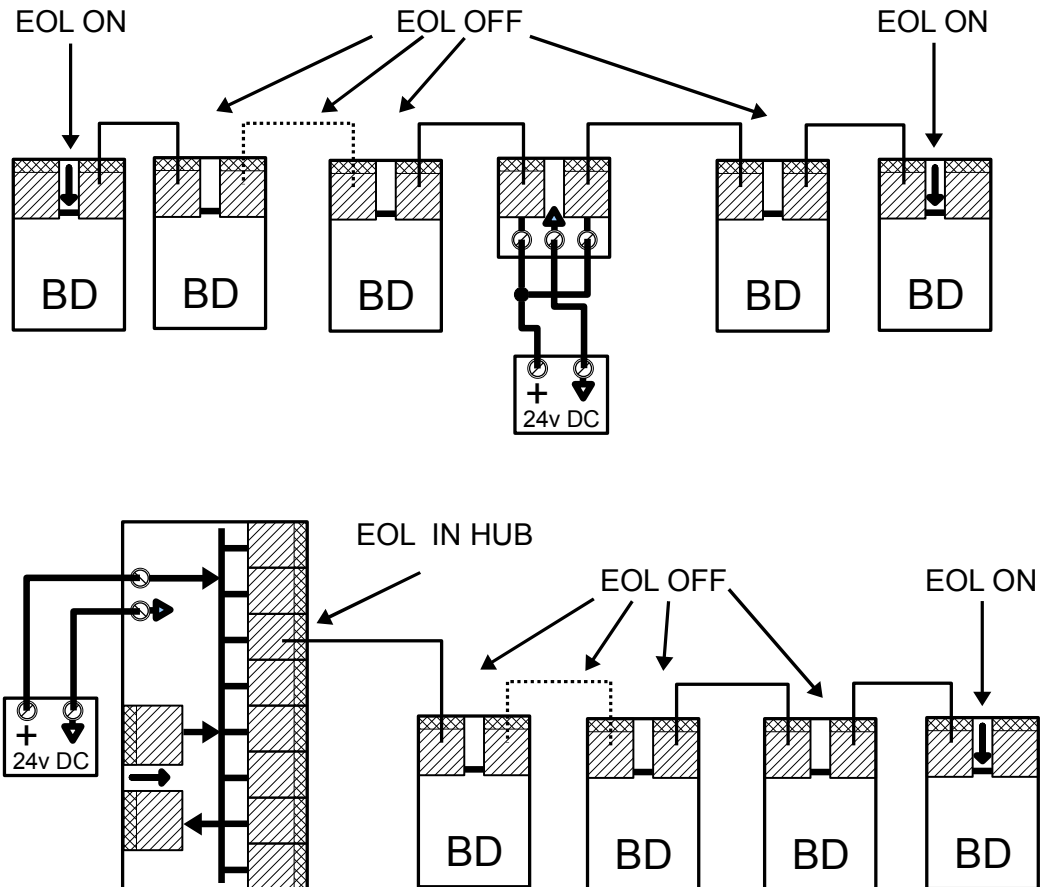

- The first/last element on a BUS line should never be a BUS linker. If this is not possible make shore that the first/last device (device with EOL ON) is very close to the power injector.

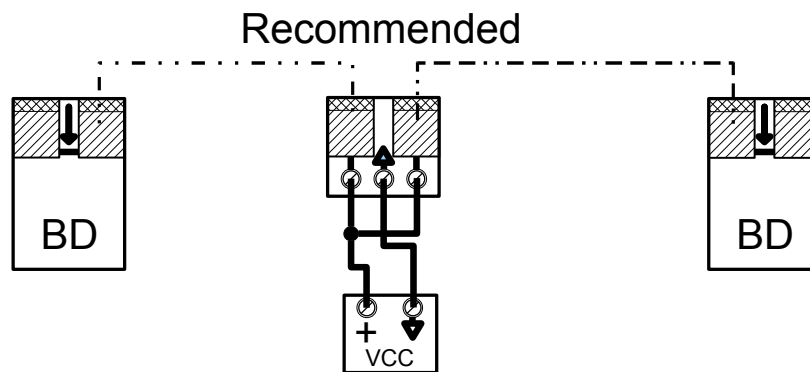
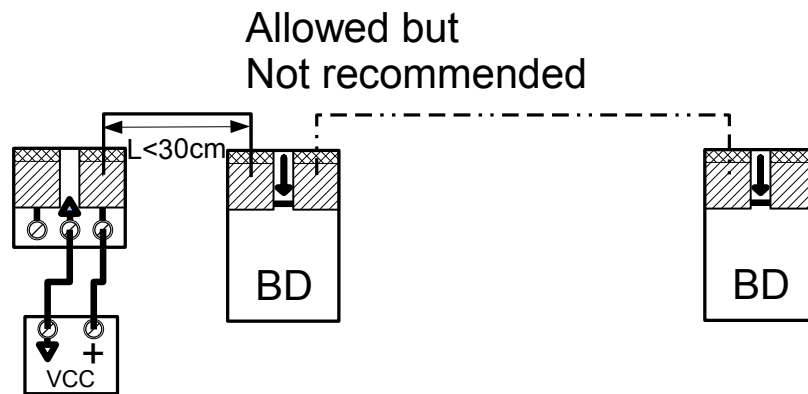
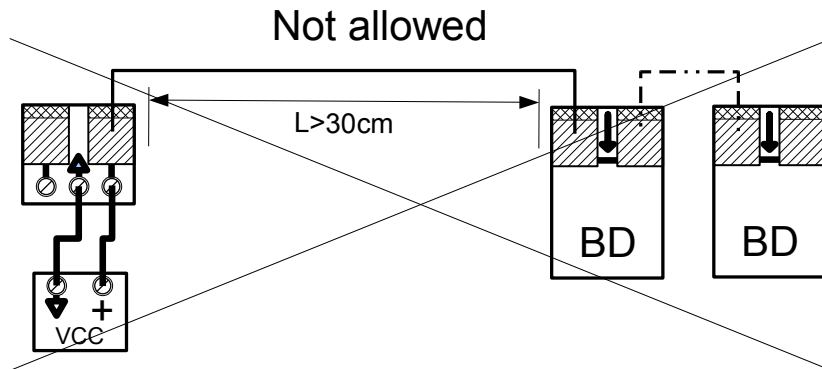

- The BUS connector is 4P4C modular jack (RJ9)
- For the BUS, 2 twisted pair AWG24 cable is used.
 - number of wires: 4 = 2 twisted pair;
 - conductor diameter: AWG24 = 0.5mm diameter
 - conductor type: rigid cooper wire
 - conductor resistance: 84 OHM/Km
 - maximum current: 1A/conductor

- Cable and connector pin-out (the same on both ends):

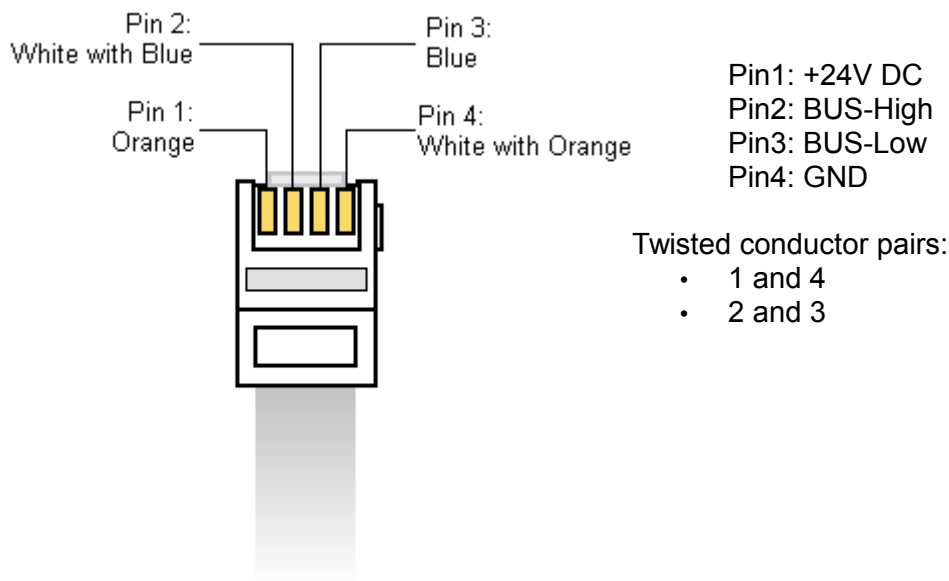

- One pair of BUS cable is used for communication
- One pair of BUS cable is used for power transfer
 - equivalent resistance (two way): 168OHM
 - maximum current: 1A

Power requirements

The most difficult job in designing a CIB-tech network is designing the cabling and placing the power supply's in such a meter that minimum amount of cable and extra devices are used.

Note: For simplifying the drawings in this section power injector symbols is used for representing power input points. The calculations are the same if the BUS line (part of the Bus line) is powered from a HUB.

The task is to connect the devices in a network, so there minimum power requirements are met. The data sheet of each CIB-tech device should be checked to determine its power requirements. Note that some CIB-tech devices can power control and sensing elements connected to it, in this case the complete power requirements of the device with its end device must be used for the calculations.

Most CIB-tech devices require a supply voltage of at least 18VDC (some eave less) so in the examples we will use this value. If the power supplies used are CIB-tech UPS type power supplies with the minimum output voltage of 20VDC, this value must be used for calculations. The situation is much better if generic 24VDC power supplies, with stable 24VDC output is used, in this case the 24 DC value must be used for calculations. In the examples we use the worst case scenario: supplies with 20VDC output.

To calculate the voltage drop on the cable OHM low must be used: $U=R*I$

In practice, the flowing formulas can be used to determine:

- voltage drop on the cable:
 $DU = I * Rk/1000 * L$
- the supply voltage of the device:
 $Ud = Us-DU$
- The minimum voltage of the power source that will meet the devices power requirements:
 $Usm = DU+Udm$
 - DU is the voltage drop on the cable
 - Ud is the supply voltage of the device

- U_{dm} is the minimum supply voltage required by the device
- U_s is the output voltage of the power source
- U_{sm} is the minimum output voltage of the power source which satisfy the devices requirements
- R_k is the two way resistance of one km of cable (168OHM for BUS and 55OHM for BB cable);
- L is the length of the cable
- I is the current consumed by the CIB-tech device, connected to the end of the cable

Example1:

A device with power consumption of 50mA and minimum operating voltage 18V is connected to a 100m long BUS line.

The voltage drop on the BUS line is: $DU = I * (R_k / 1000) * L = 0.05 * (168 / 1000) * 100 = 0.84V$
 So the minimum voltage that the power supply must guaranty is $U_{sm} = DU + U_{dm} = 0.84 + 18 = 18.84V$

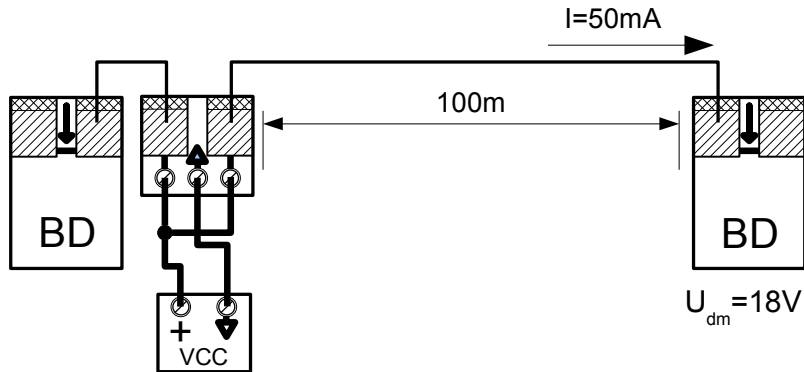

As it is in usual case, one power source supplies more than one CIB-tech device distributed on the same bus line in which case the calculation is getting more complicated:

Example2:

There are three devices connected to the bus line. The minimum operating voltage for each is 18V.

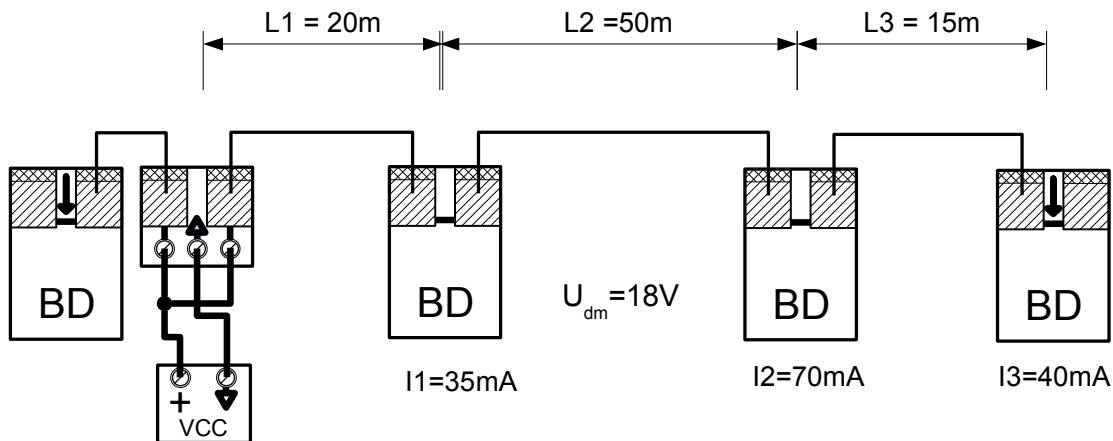

The voltage drop on BUS section "3" is:

$$DU_3 = I_3 * R_k / 1000 * L_3 = 0.04 * 168 / 1000 * 15 = 0.1008V$$

The voltage drop on BUS section "2" is:

$$DU_2 = (I_3 + I_2) * R_k / 1000 * L_2 = (0.04 + 0.07) * 168 / 1000 * 50 = 0.942V$$

The voltage drop on BUS section "1" is:

$$DU_1 = (I_3 + I_2 + I_1) * R_k / 1000 * L_1 = (0.04 + 0.07 + 0.35) * 168 / 1000 * 20 = 0.4872V$$

The voltage drop on the BUS line is $DU = DU_1 + DU_2 + DU_3 = 0.1008 + 0.942 + 0.4872 = 1.53V$

So the minimum voltage that the power supply must guaranty is $U_{sm} = DU + U_{dm} = 1.53 + 18 = 19.53V$

Calculating in this detail a complex CIB-tech network is rather difficult, so in surtain situations some simplifications can be made:

- If the distance between the power source and the first device is much greater then the distance

between the first device and the last, than the distance between the devices can be ignored. This is a usual case in DIN-rail type installations.

In this case this simplified formula can be used: $DU = (I_1+I_2+I_3+...+I_n) * R_k / 1000 * (L_1 + L_n)$

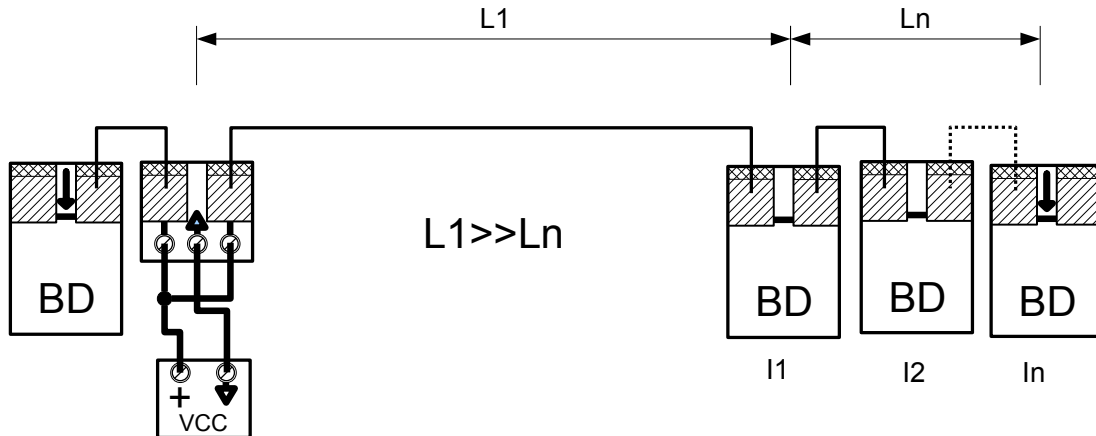

- The same can be applied if the entire length of the BUS line is very short.

$$DU = (I_1+I_2+I_3+...+I_n) * R_k / 1000 * L$$

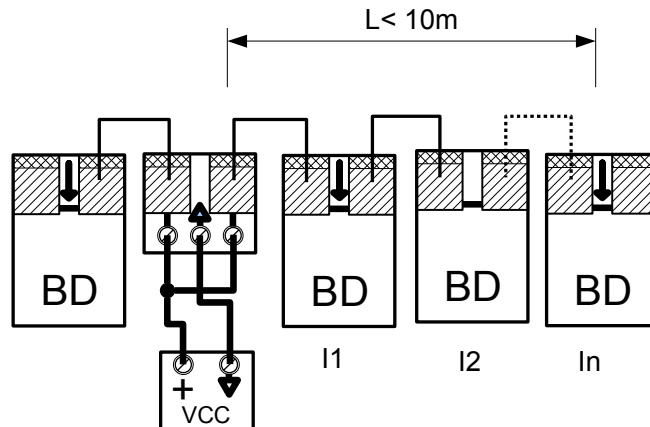

NOTE In both of these cases the calculation is not accurate, but there is within acceptable limits.

In case of long BUS lines with many CIB-tech devices more than one power entry points are required. In these cases there are two possibilities:

- use of a separate power supply at each power entry point

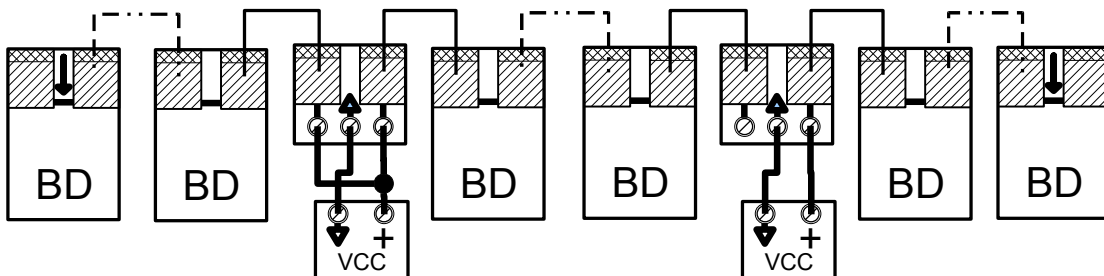

- use the same power supply for more than one (all of the the) power entry points.

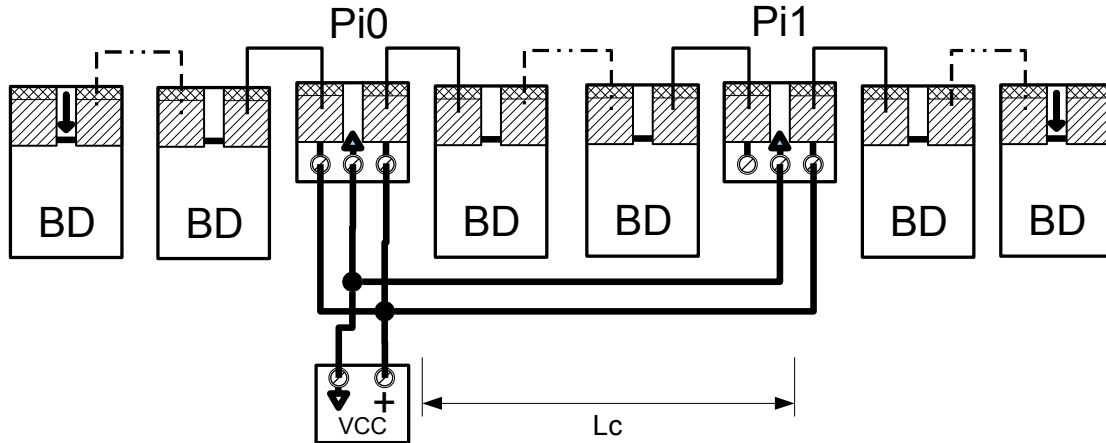

In this case the voltage drop on the cable between the power supply and the power input point (ex. power injector) must be taken into consideration. The voltage drop on the cable depends on the thickness of the cable used.

In the drawing above we consider the cable between the power supply and Pi0 as “zero length” (very short and its resistance can be ignored). But the voltage drop between the power supply and Pi1 must be taken into consideration:

- Cable length (in meter): L_c
- Current necessary at Pi1: I_1 (the sum of the current necessary to all the devices powered from Pi1)
- Minimum voltage at Pi1: U_{1m} (the minimal voltage level that is necessary to power the devices connected to Pi1- use the method described above to calculate it)
- Supply voltage: U_s
- Voltage drop on the cable: D_{uc}

The maximum voltage drop allowed: $D_{uc} = U_s - U_{1m}$

The maximum resistance of the cable allowed (for a cable of LC length): $R_c = D_{uc} / I_1$

The resistance of one Km cable (taking into consideration that there is a pair of conductors):

$$R_{ck} = (1000 * R_c) / (2 * L_c)$$

Use the AWG rating table below to determine the thickness of the cable that is necessary.

AWG	Conductor diameter (mm)	Conductor area (mm ²)	Resistance of copper wire (OHM/km)
10	2.588	5.26	3.277
11	2.305	4.17	4.132
12	2.053	3.31	5.211
13	1.83	2.62	6.571
14	1.628	2.08	8.286
15	1.422	1.65	10.45
16	1.291	1.31	13.17
17	1.150	1.04	16.61
18	1.02	0.823	20.95
19	0.912	0.653	26.42
20	0.812	0.518	33.31
21	0.723	0.410	42.00
22	0.644	0.326	52.96

23	0.573	0.26	66.79
24	0.511	0.21	84.22

Example:

Some devices are powered from a power injector. Doing the calculation on the BUS line voltage drop the following results:

Minimum voltage at the power injector: $U_{1m} = 19.53V$

Current necessary at the power injector: $I_1 = 145mA$

The Length of the cable from the supply to the power injector: $L_c = 50m$

Supply voltage: $U_s = 20V$

The maximum voltage drop allowed: $D_{uc} = U_s - U_{1m} = 20 - 19.53 = 0.47v$

The maximum resistance of the cable (two conductors of 50m): $R_c = D_{uc}/I_1 = 0.47/0.145 = 3.24$

The resistance of one Km cable (taking into consideration that there is a pair of conductors):

$$R_{ck} = (1000 * R_c) / (2 * L_c) = (1000 * 3.24) / (2 * 50) = 32.4 \text{ OHM}$$

Looking at the AWG table that results a 19AWG cable, or a $0.75mm^2$ cable according to European standards.

In case that more than one power injector is connected to the same cable, the calculations are becoming more difficult. The voltage drop on each section of the cable must be calculated to determine the minimum thickness of the cable.

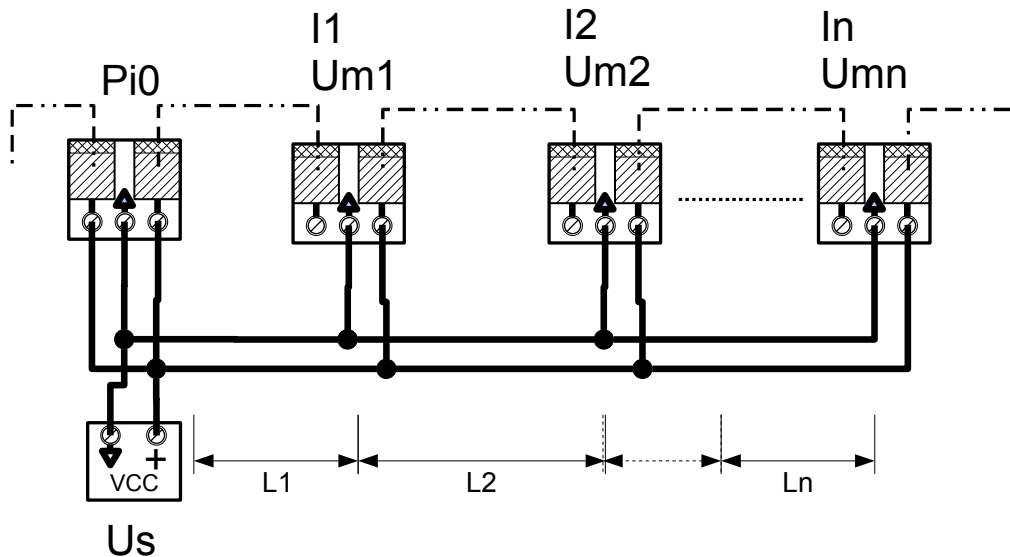

We know the cable lengths between the power injectors and the current and minimum voltage required at the power injector. To simplify the calculations, we use the same type of cable for each segment.

Calculate the voltage drop for each segment:

$$DU_1 = (I_1 + I_2 + \dots + I_n) * (R/1000) * L_1$$

$$DU_2 = (I_2 + I_3 + \dots + I_n) * (R/1000) * L_2$$

⋮

⋮

$$DU_n = I_n * (R/1000) * L_n$$

Set up the inequality for determining R

$$U_s - U_{m1} \geq 2 * DU_1$$

$$U_s - U_{m2} \geq 2 * DU_1 + 2 * DU_2$$

⋮

⋮

$$U_s - U_{mn} \geq 2 * DU_1 + 2 * DU_2 + \dots + 2 * DU_n$$

Resolving the inequality will determine the maximum resistance/km of cable that satisfies the systems requirements.

Example:

There are 3 power injectors that are connected to a power supply with a cable:

- Us = 20v
- Um1 = 19.5v
- Um2 = 18.7v
- Um3 = 19.3v
- I1 = 300mA
- I2 = 700mA
- I3 = 400mA
- L1 = 50m
- L2 = 10m
- L3 = 30m

Calculate the voltage drop for each segment:

$$DU1 = (I1+I2+I3) \cdot (R/1000) \cdot L1 = (0.3+0.7+0.4) \cdot (R/1000) \cdot 50 = 0.07 \cdot R$$

$$DU2 = (I2+I3) \cdot (R/1000) \cdot L2 = (0.7+0.4) \cdot (R/1000) \cdot 10 = 0.011 \cdot R$$

$$DU3 = I3 \cdot (R/1000) \cdot L3 = 0.4 \cdot (R/1000) \cdot 30 = 0.012 \cdot R$$

The inequality:

$$Us - Um1 \geq 2 \cdot DU1 \quad 20 - 19.5 \geq 2 \cdot 0.07 \cdot R$$

$$Us - Um2 \geq 2 \cdot DU1 + 2 \cdot DU2 \quad 20 - 18.7 \geq 2 \cdot 0.07 \cdot R + 2 \cdot 0.011 \cdot R$$

$$Us - Um3 \geq 2 \cdot DU1 + 2 \cdot DU2 + 2 \cdot DU3 \quad 20 - 19.3 \geq 2 \cdot 0.07 \cdot R + 2 \cdot 0.011 \cdot R + 2 \cdot 0.012 \cdot R$$

$$R \leq 3.57$$

$$R \leq 8.02$$

$$R \leq 3.76$$

This results that the cable used must have a maximum resistance om 3.57OHM/km. Looking at the AWG table that results a 10AWG cable. It dose not results directly from the AWG table but according to European cable markings a 5mm² cable is suitable.

- Voltage Drop on the BB cable.

If a HUB is powered via its IBB connector (not via its dedicated power connector) the voltage drop on the BB cable must be taken into consideration. Note that power transfer on the backbone should only be used if the distance between the HUBs is short, otherwise separate power supply is recommended for each HUB. The voltage drop calculatin is similar to the voltage drop on the BUS cable, with the difference that the current required for the HUB and all the devices powered from it must be calculated first. The formula for the calculation is available in the given HUBs data sheet

Example:

Two HUBs are powered from a UPS type power supply via power supply monitor.

The cable lengths L1 = 5m, L2 = 3.

The current required for the HUBs are calculated using the formula in the HUBs data sheet. Note that first I2 must be calculated because to calculate I1, I2 is required. I2=1A, I1=2.8A

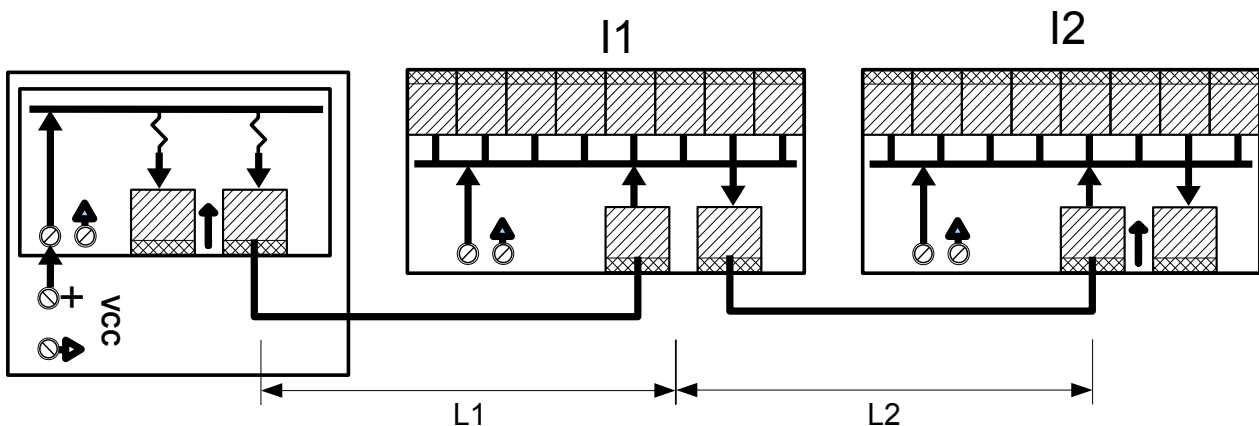

The voltage drop on the cables:

Voltage drop on section 1: $DU1 = I1 \cdot (Rk/1000) \cdot L1 = 2.8 \cdot (55/1000) \cdot 5 = 0.77$

Voltage drop on section 2: $DU2 = I2 \cdot (Rk/1000) \cdot L2 = 1 \cdot (55/1000) \cdot 3 = 0.165$

Total Voltage drop: $DU = DU1 + DU2 = 0.77 + 0.165 = 0.935$

Note that even with these rather short cables the voltage drop is significant, and the bus lines must be designed correctly so the minimum voltage requirements of the devices to be met.

Examples of CIB-tech networks

In these examples the problem of the voltage drop on the cable is not treated. When designing a CIB-tech network the voltage drops on the cable should be calculated according to the section above.

In the drawings a 2x1A power injectors are used. Check the data sheet of the given power injector to determine its power rating. Also note that due to voltage drop on the cable the full 1A capacity of power injector can only be used if the devices are close to the power injector.

In all of these drawings, different power supplies are used every place power is needed. It is possible to use the same power supply for all the power input points with the condition that the voltage drop on the cable from the power supply to the power injector is within limits.

Linear BB-less networks:

The simplest CIB-tech network

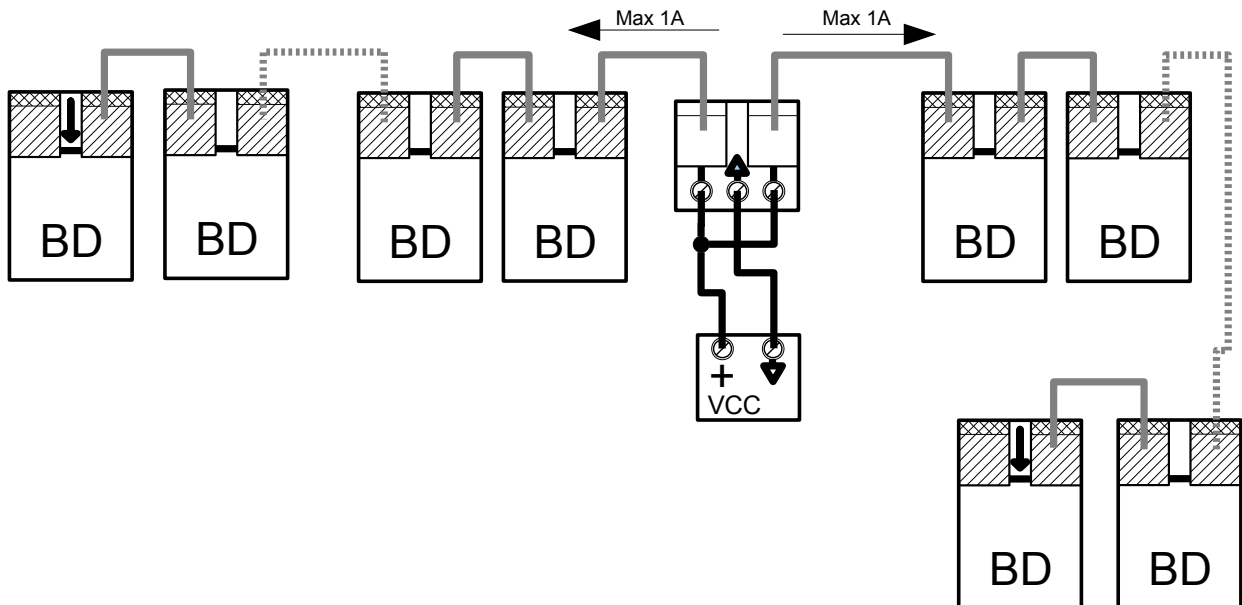

The bus line can be extended using power injector:

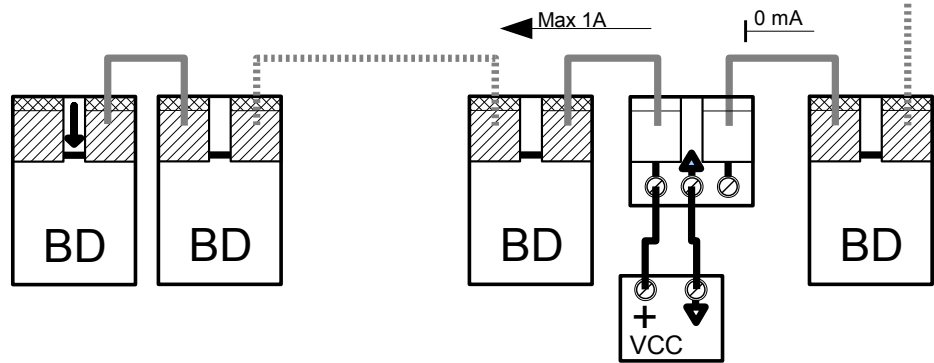
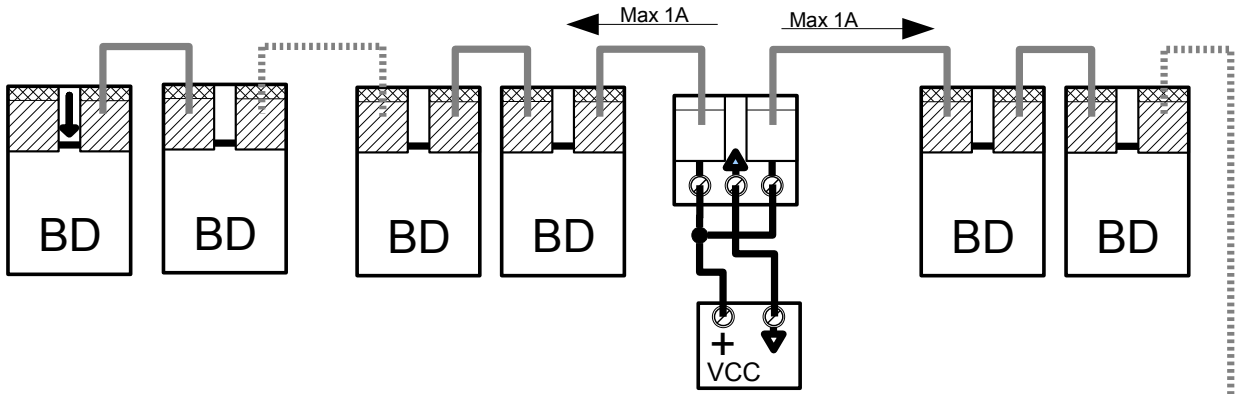

The power injector can be used for separating the VCC line of the two power supplies

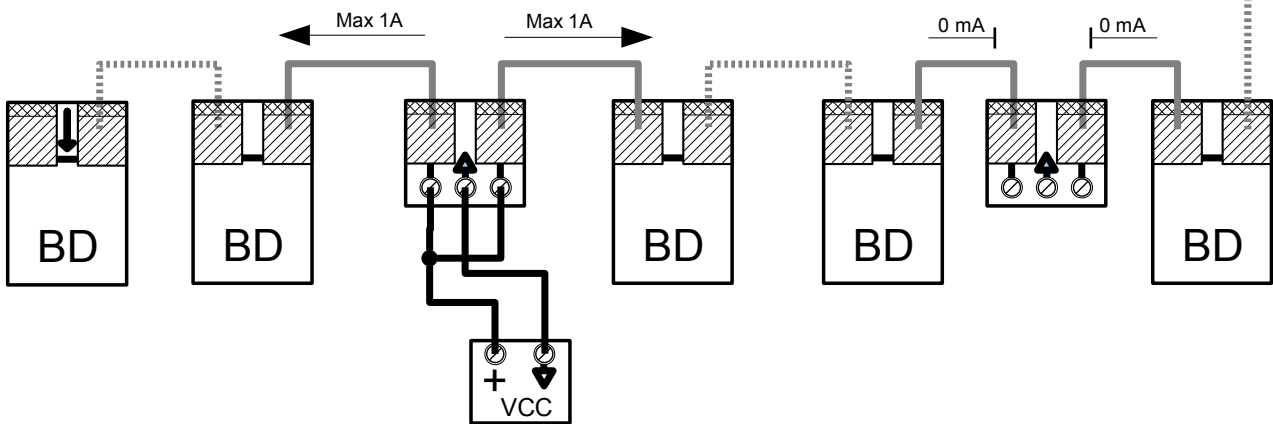
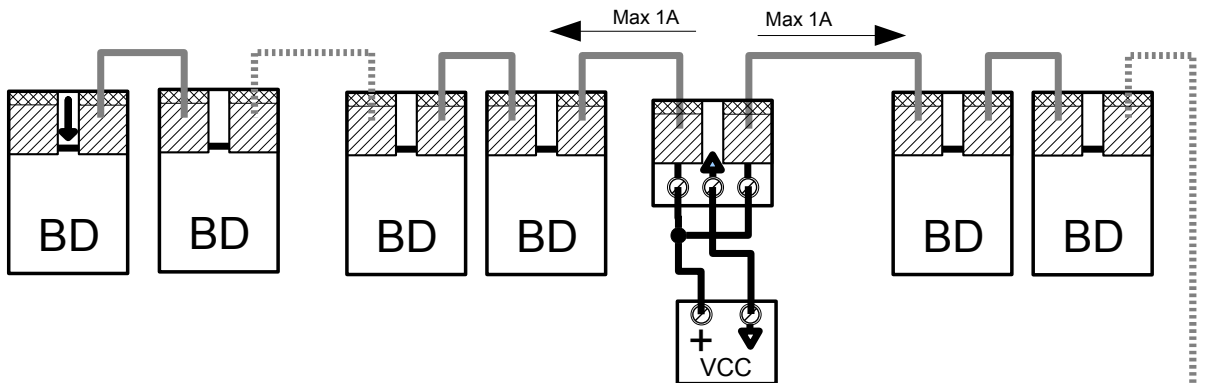

The largest linear CIB-tech network can contain a maximum of 120 BUS devices and many power injectors in different connection.

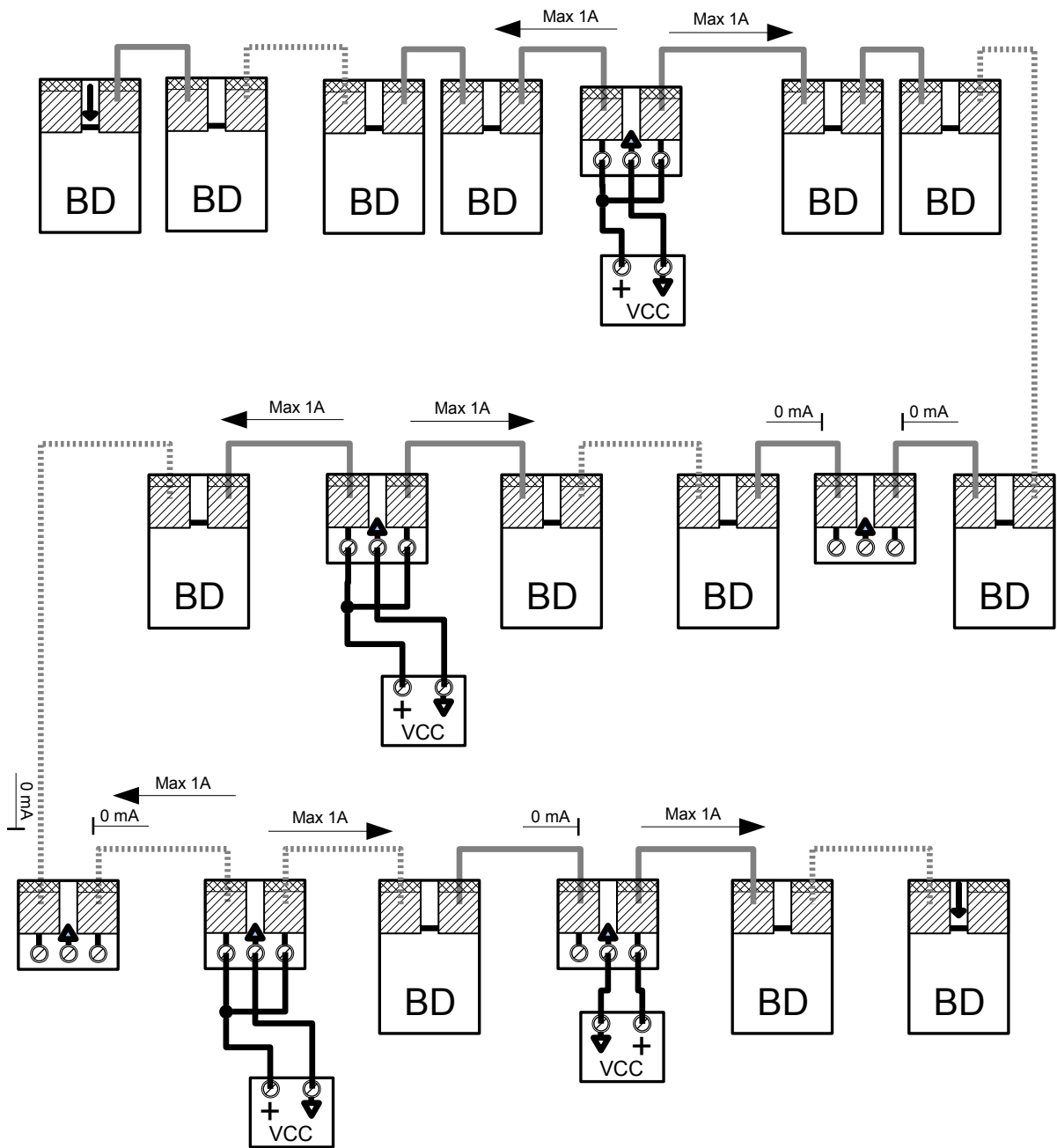

CIB-tech network with zero length BB-BUS:

The current implementations of the CIB-tech HUB has a maximum 400mA power output/BUS connector, this value is used in the drawings. Future CIB-tech HUB may have different power output capability. Check the data sheet of the given HUB to determine its power ratings.

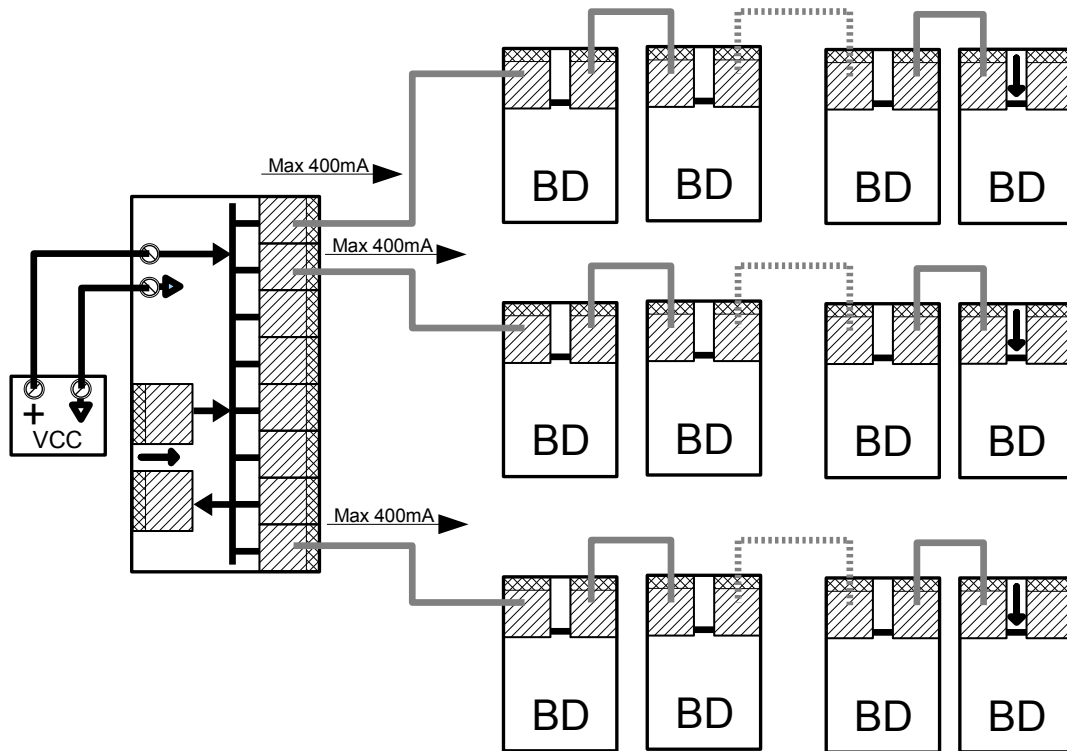

The BUS lines connected to a HUB can be extended using power injectors just like in the case of linear CIB-tech networks.

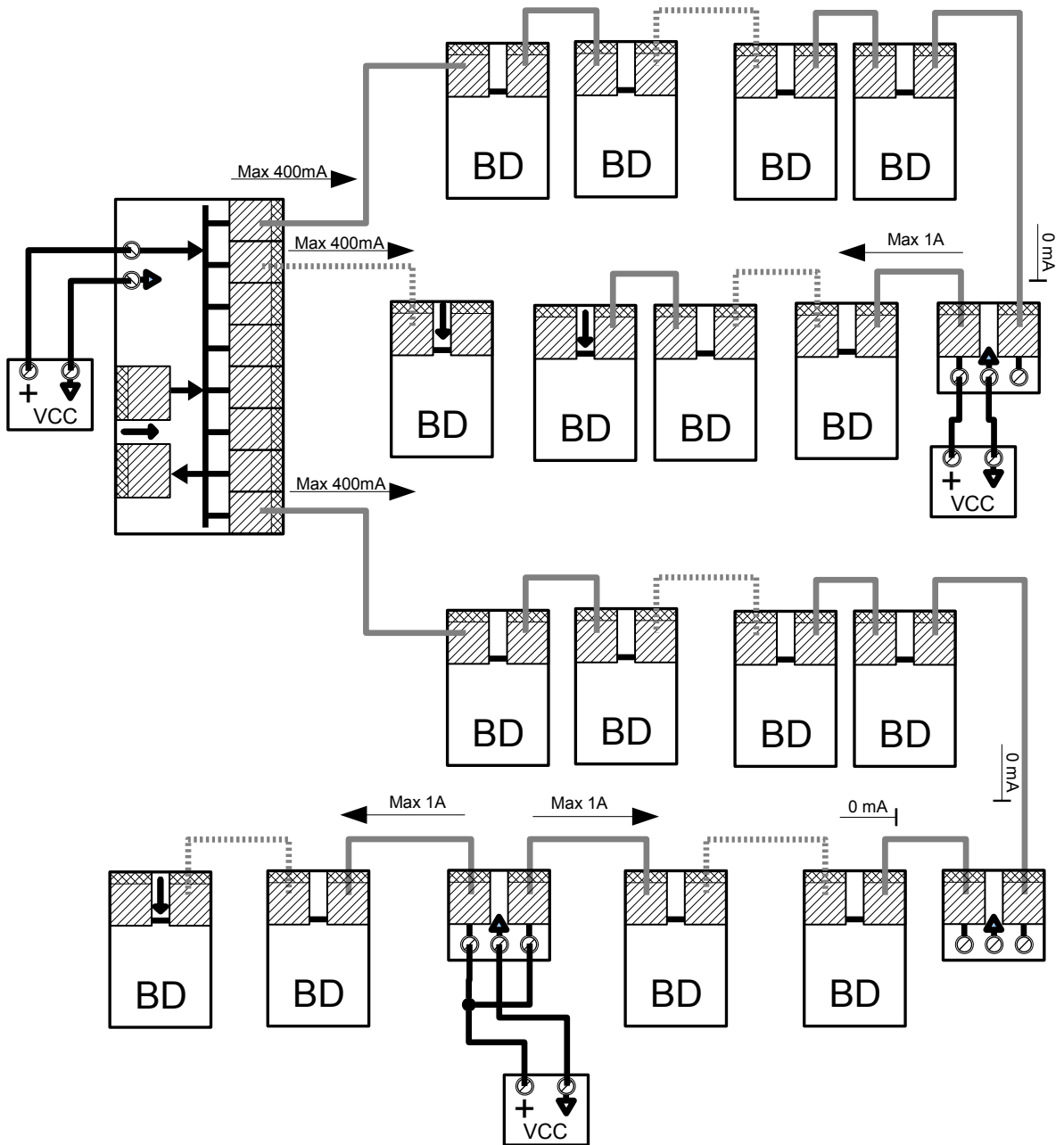

CIB-tech network with real BB-BUS:

The voltage drop on the BB-cable must be taken into consideration. This solution should only be used if the HUBS are close together

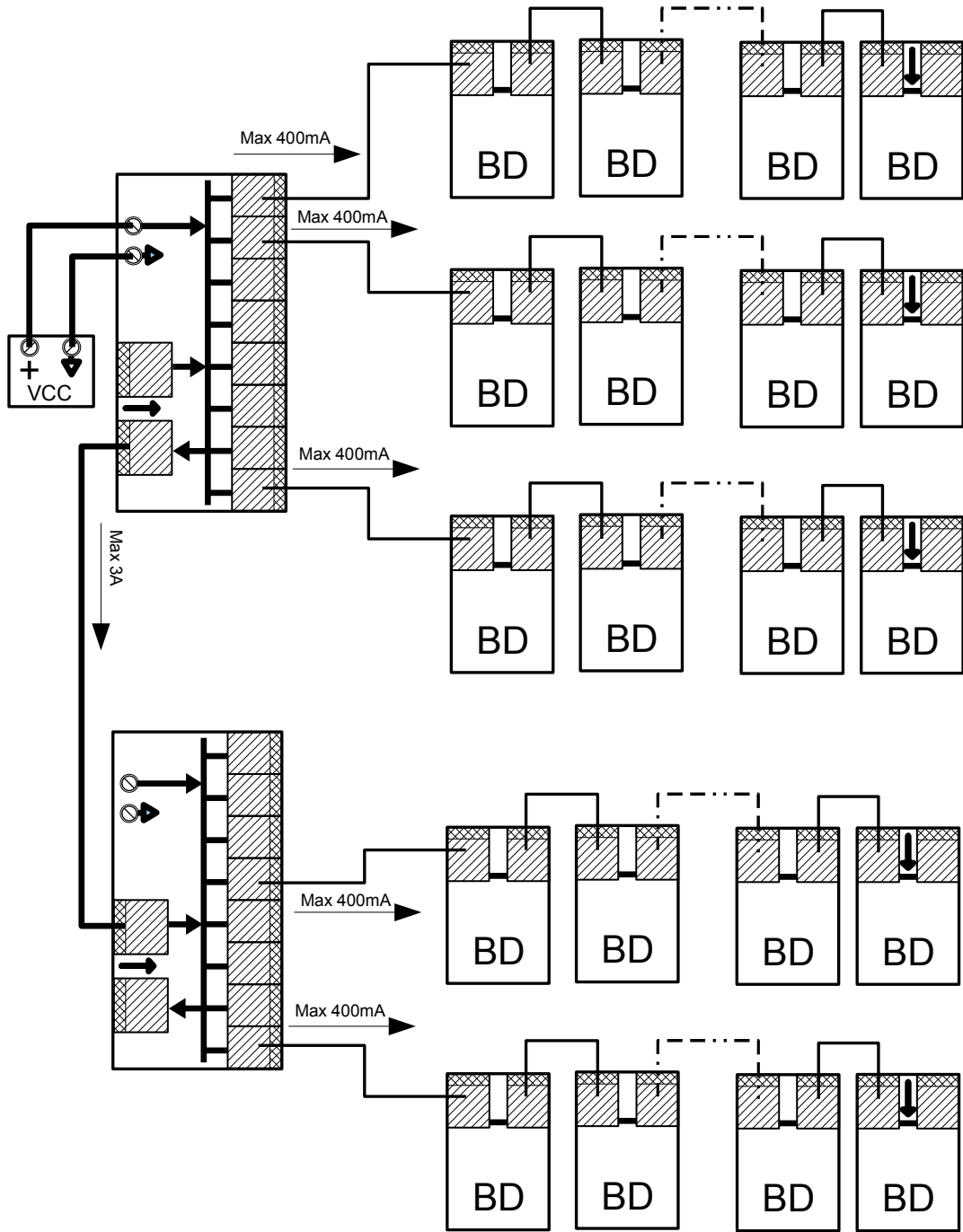

If there is a long distance between the HUBs, different power supply should be used for powering them.

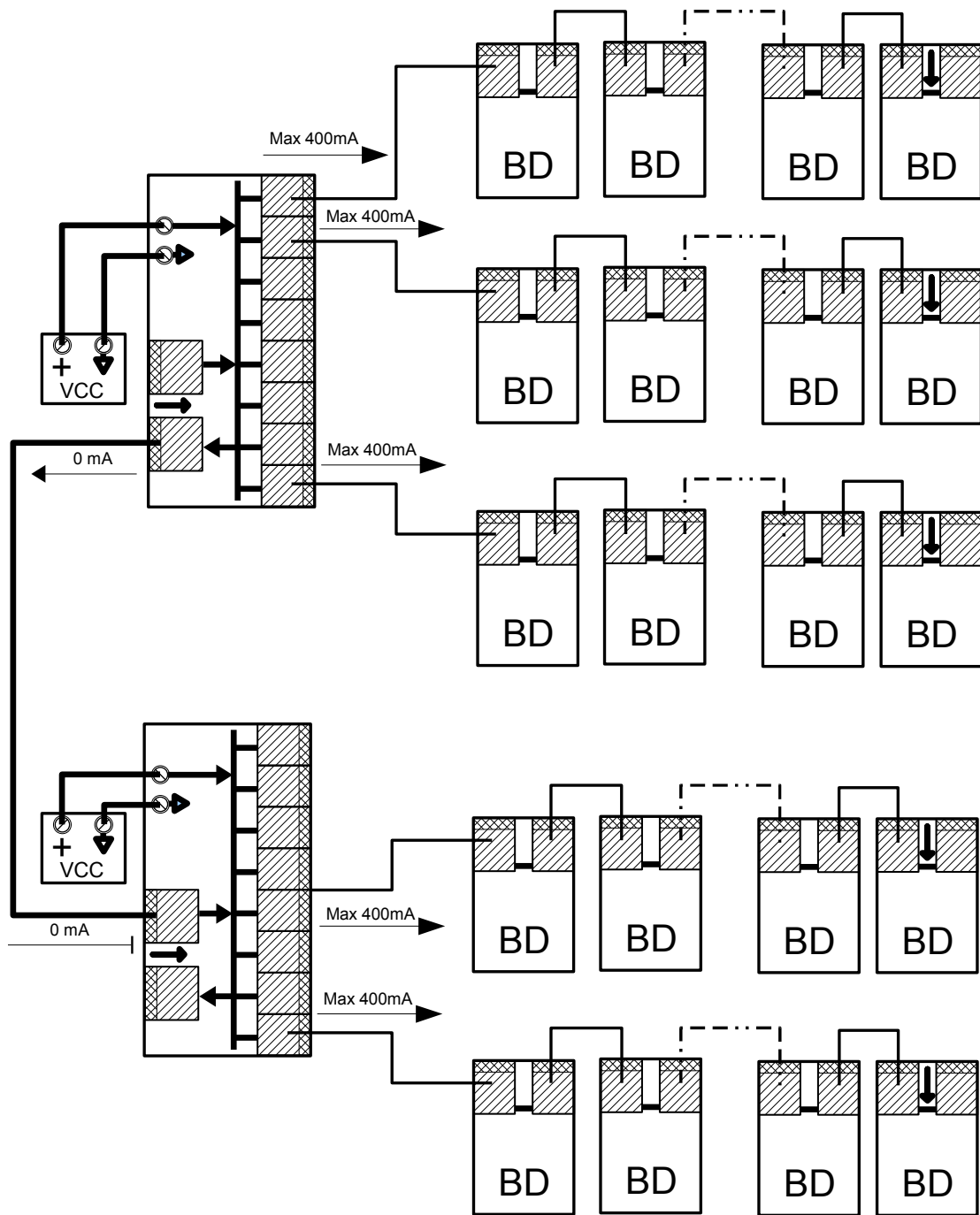

The power supply monitor can be used to insert power to the BB-BUS.

Note: the power supply monitor has both of its fuses on and the IBB BUS connector is used at both HUBs

The power supply monitor can output a maximum of 3A on both of its BB-connectors (a that is a total of 6A).

Note that this is the limit of the power supply monitor device, the real limit is the limit of the power supply what it monitors. So the total output of the power supply monitor is equal with the power supplies capacity (1.8A respectively 5A using the current UPS type CIB-tech power supplies)

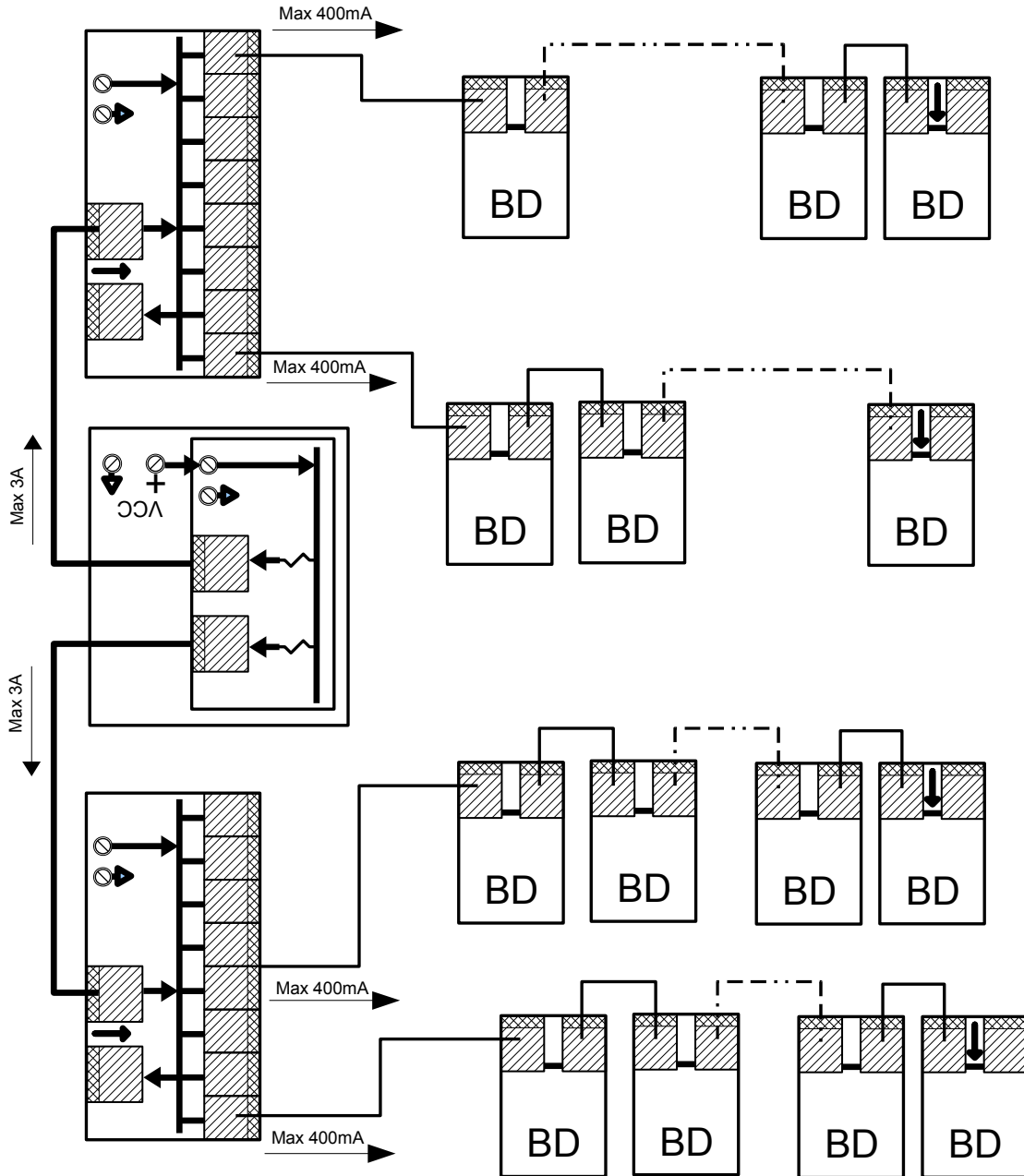

The BB-BUS can be extended using more HUBs and optionally power supply monitors. Note that HUB2 can be powered with maximum 3A minus the power necessary to HUB1 and to all of the devices connected to it. One of the fuse is removed from supply monitor SM2 to avoid the connection of the VCC lines of the two supplies. The cable between SM1, HUB1 and HUB2 as well as between SM2 and HUB3 must be kept short to avoid voltage drop on the BB cable.

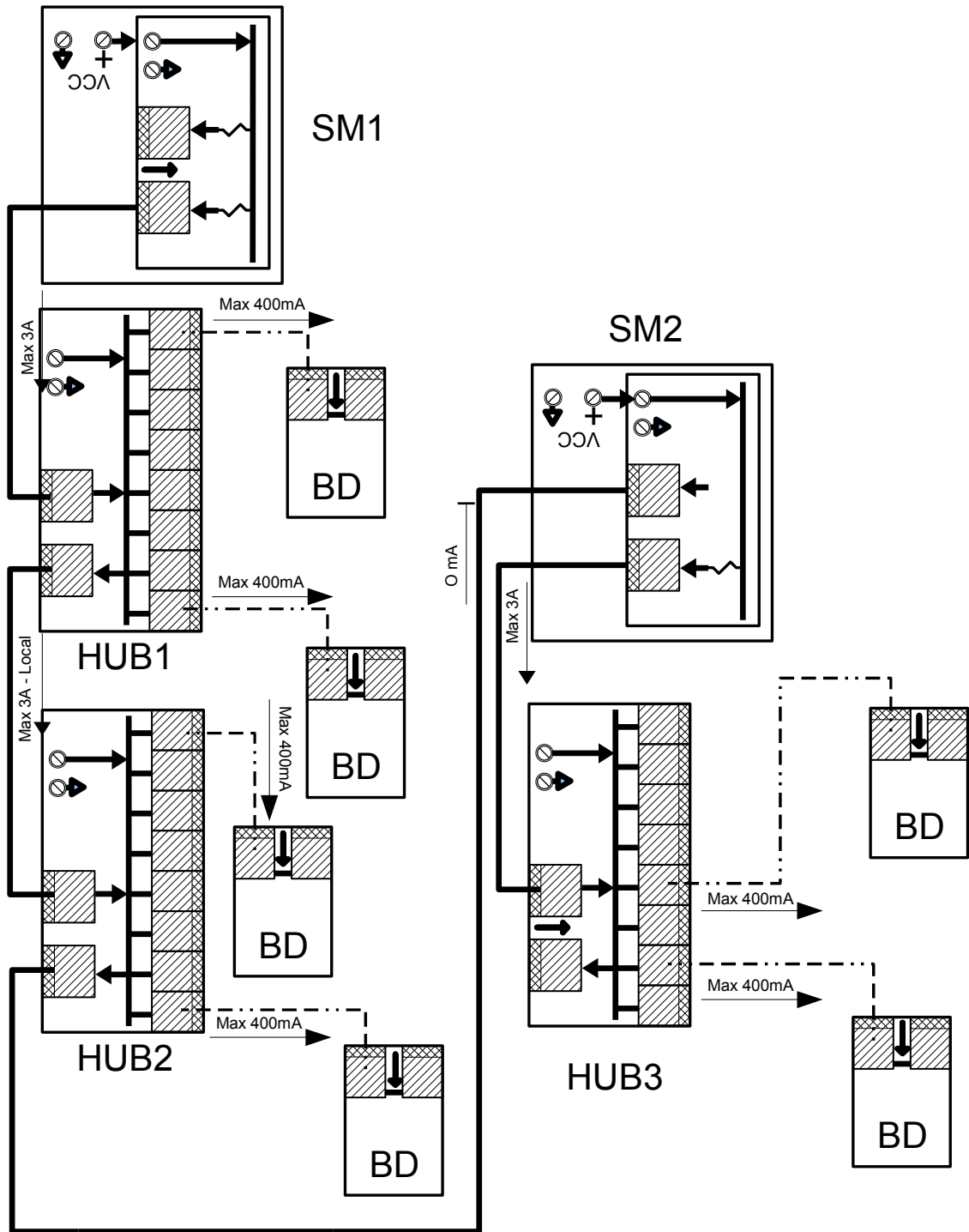

Technical Support:

<http://www.ibs-smarthouse.com/>
info@ibs-smarthouse.com

All trademarks used in this document are properties of their respective owners.
[The manufacturer reserves the right to change the technical features of the products and its connection/installation requirements without prior notice.](#)